

# STREAMLINE ALLSKY XR

12 km range pulsed scanning LiDAR system



## MAIN FEATURES

- Range: up to 12 km
- Fully user configurable scan patterns and schedules
- Overlapped range gates and variable gate length (up to 7900)
- Direct access to raw data
- Light and compact Halo design (2-person deployable)
- High reliability with Lumibird laser inside

## MAIN APPLICATIONS

- **METEOROLOGY**
- **CLIMATE AND ENVIRONMENTAL MONITORING**
- **ON-SHORE SITE ASSESSMENT**
- **WAKE STUDIES**
- **AIRPORT SAFETY**



“

THE **STREAMLINE ALLSKY XR** is a self-contained, turnkey scanning pulsed LiDAR system designed specifically for meteorology and wind energy studies as well as airport safety. These rugged units are easy to install and operate in all weather conditions. The hardware configuration gives an easy access to raw data for post treatment and analysis. This LiDAR benefits from Lumibird's >25 years of laser design and manufacturing expertise and Halo Photonics' fast data processing algorithms.

”

01/26 - Lumibird reserves the right to modify the specifications without prior notice. Photos are not contractual.

[www.halo-photonics.com](http://www.halo-photonics.com)



Lumibird has locations across the globe that are available to provide support for any product, service or inquiry. Visit [www.lumibird.com](http://www.lumibird.com) to connect with any of our global sites.

# STREAMLINE ALLSKY XR

## 12 km range pulsed scanning LiDAR system



Measurement performance	Value	Notes
Beam geometry	Scanning laser head, 360° azimuthal and -15 to 195° elevation ranges	Configurable (stare, VAD, RHI, and wind profile) and customer step/stare or continuous trajectory
Scanning head resolution	0.01°	
Max scanning speed	Max 72°/s,	Recommended 0-36°/s
Measurement range	From 70 m up to 12 km	Optimal sampling: 4.5 km
Accumulation time	0.1 to 30 s	
Range gates	Up to 7900	User configurable, including overlapping. (3950 gates for 50 MHz)
Spatial resolution	12 to 210 m	By step of 3 or 1.5 m (100MHz option)
Radial wind speed	+/- 19 m/s	+/-38 m/s with 100 MHz option
Speed accuracy	≤ 0.2 m/s	

Environmental specifications	Value	Notes
Operating temperature	-20 to +45 °C	
Operating humidity	0 to 95 %	Non condensing
Rain protection	Brush	
Snow protection	Brush	
Laser safety compliance	Class 1M	IEC60825-1:2014
Housing classification	IP66	

Utility	Value	Notes
System dimensions	1020 x 740 x 870 mm <sup>3</sup>	Height x width x depth
Weight	85kg	
Direct input power supply	24 VDC +/-10 %	
AC/DC power supply input	100-240 VAC (50/60 Hz)	
Power consumption	Typ 200W	< 525W over operating temperature range

Data Output	Value	Notes
Output data	User defined typ 1s • Time-stamped radial velocity, SNR and spectral width vs range. • Time-stamped horizontal wind speed and direction vs height in wind profile mode • GPS coordinate	
Data storage	1 TB SSD	Additional sizes available on request
Data file format	Text file (.hpl)	
Communication	LAN, USB	
Time synchronization	GPS, NTP	

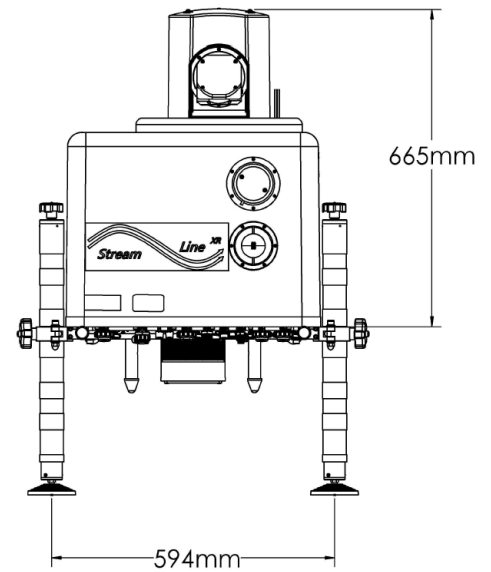

### OPTIONS

- 100 MHz data acquisition
- Depolarization



Wake effect studies



Climate and Environmental monitoring

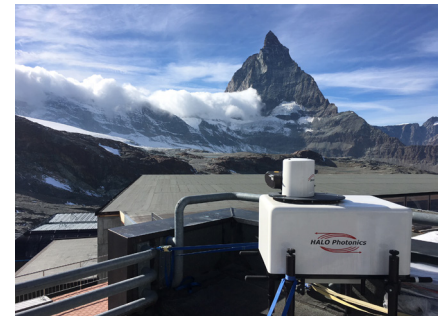

Meteorology

[www.halo-photonics.com](http://www.halo-photonics.com)



Lumibird has locations across the globe that are available to provide support for any product, service or inquiry. Visit [www.lumibird.com](http://www.lumibird.com) to connect with any of our global sites.